

Miele

MasterCool Refrigeration
Side-by-Side Merging Combinations
For SF Models

KSK 1003



Side-by-Side Merging Kit KSK 1003

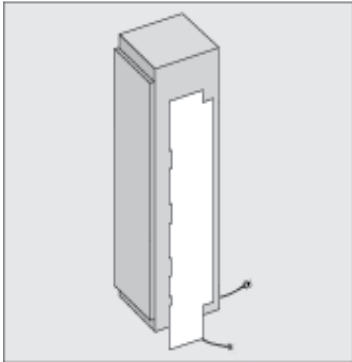

SPECIFICATIONS

KSK 1003 – Item 10562720

Electrical

Power Cord Direct connection to left-standing appliance

Support

Call Miele (800) 999-1360

Miele Website www.mieleusa.com

20/20 Link 2020technologies.com

This merging kit should be used for side-by-side installation of the following models:

- K 18x1 SF, K 19x1 SF, K 18x3 SF, K 19x3 SF
- F 14x1 SF, F 18x1 SF, F 19x1 SF, F 14x3 SF, F 18x3 SF, F 19x3 SF
- KF 18x1 SF, KF 19x1 SF, KF 18x3 SF, KF 19x3 SF
- KWT 16x1 SF, KWT 16x3 SF

For side-by-side installation of appliances with a stainless-steel front (SF), you also need a **Top-frame**. Please contact Miele to obtain a top-frame in the required width. The width of the Top-frame corresponds to the totale width of you side-by-side combination.

Side-by-Side Merging Kit KSK 1003

Side-by-side

... without partition

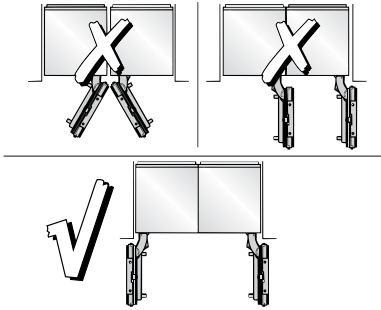

If the appliances are installed directly next to each other (without a partition), they need to be attached together. A heating mat must also be installed. This will help avoid condensation and prevent damages.

... with partition

If there is a partition with a thickness **less than 6 5/16" (160 mm)** between the adjacent appliances, then each appliance should be individually installed within its own niche using the mounting accessories included.

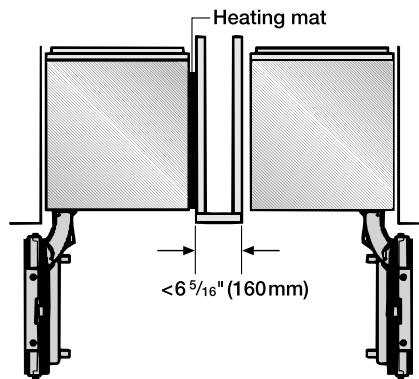

In this case, you will only need the heating mat from the "Merging kit" to avoid condensation and prevent damages. Please be aware the left unit's cutout will require an additional 1/8" (3 mm) to the width to allow installation of the heating mat.

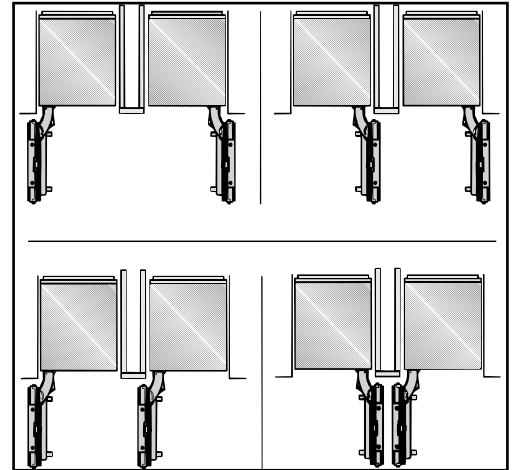

HEATING MAT TRANSFORMER PLUG DETAILS FOR KSK 1003

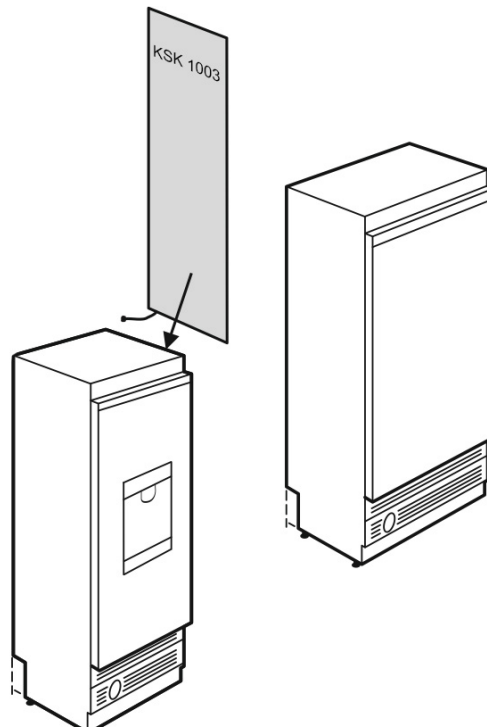

Location Codes

- *KSK 1003- Heating mat connects directly to left-standing appliance*

Notes

- *Merging kit must be used when combining units*
- *All Installations must be done in accordance with local codes*

Product and Cut-out Dimensions
48" Side-by-Side Combination

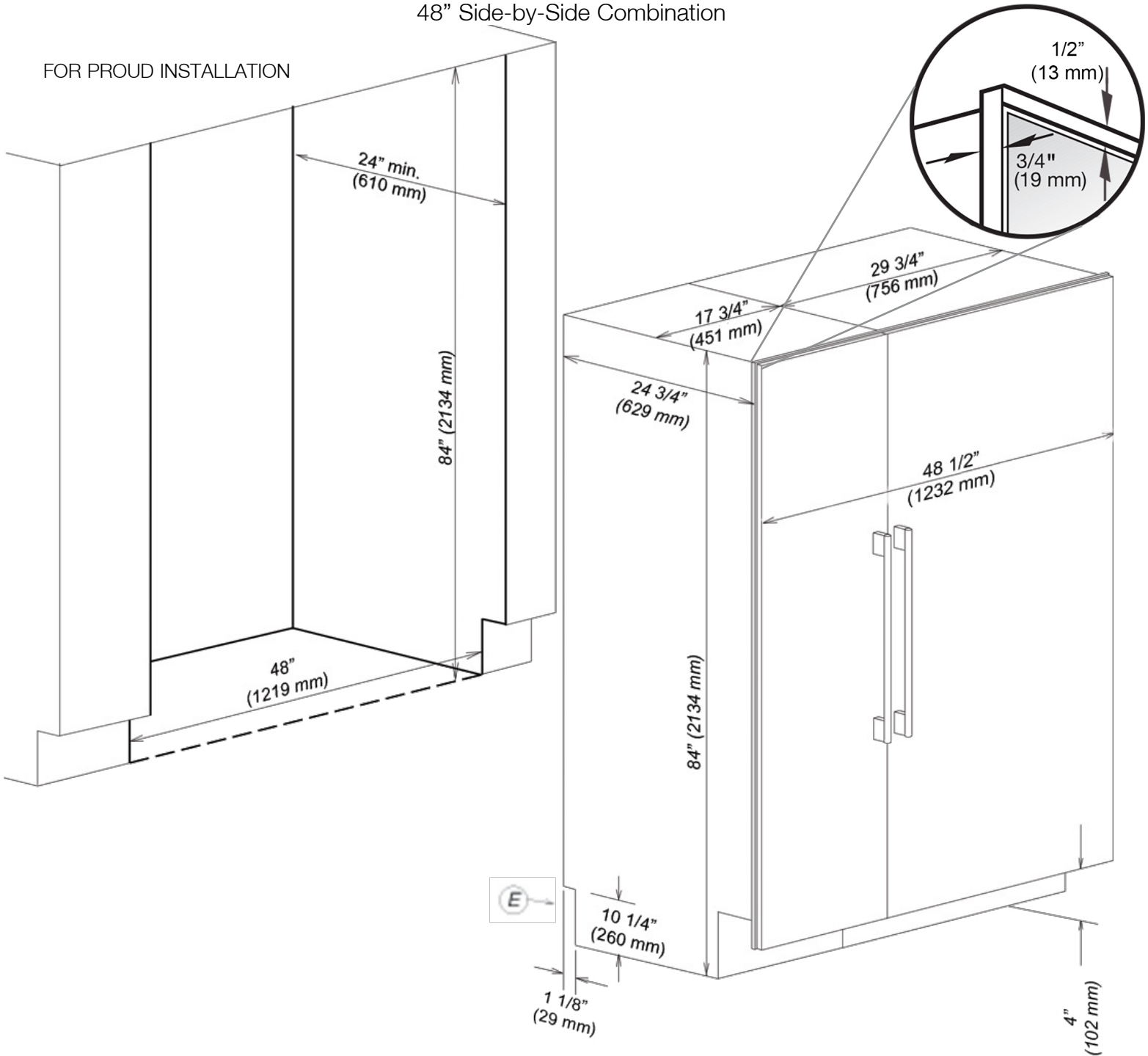

Location Codes

E- power cord for refrigeration unit- 5 foot- NEMA 5-15 molded plug power cord connects lower left rear of units

Notes

- Merging kit must be used when combining units
- KFT1048SS top frame piece must be used when combining units
- All Installations must be done in accordance with local codes
- Sides of adjoining cabinets should be filled (flush to frame) to insure proper fit and finish

Product and Cut-out Dimensions
48" Side-by-Side Combination

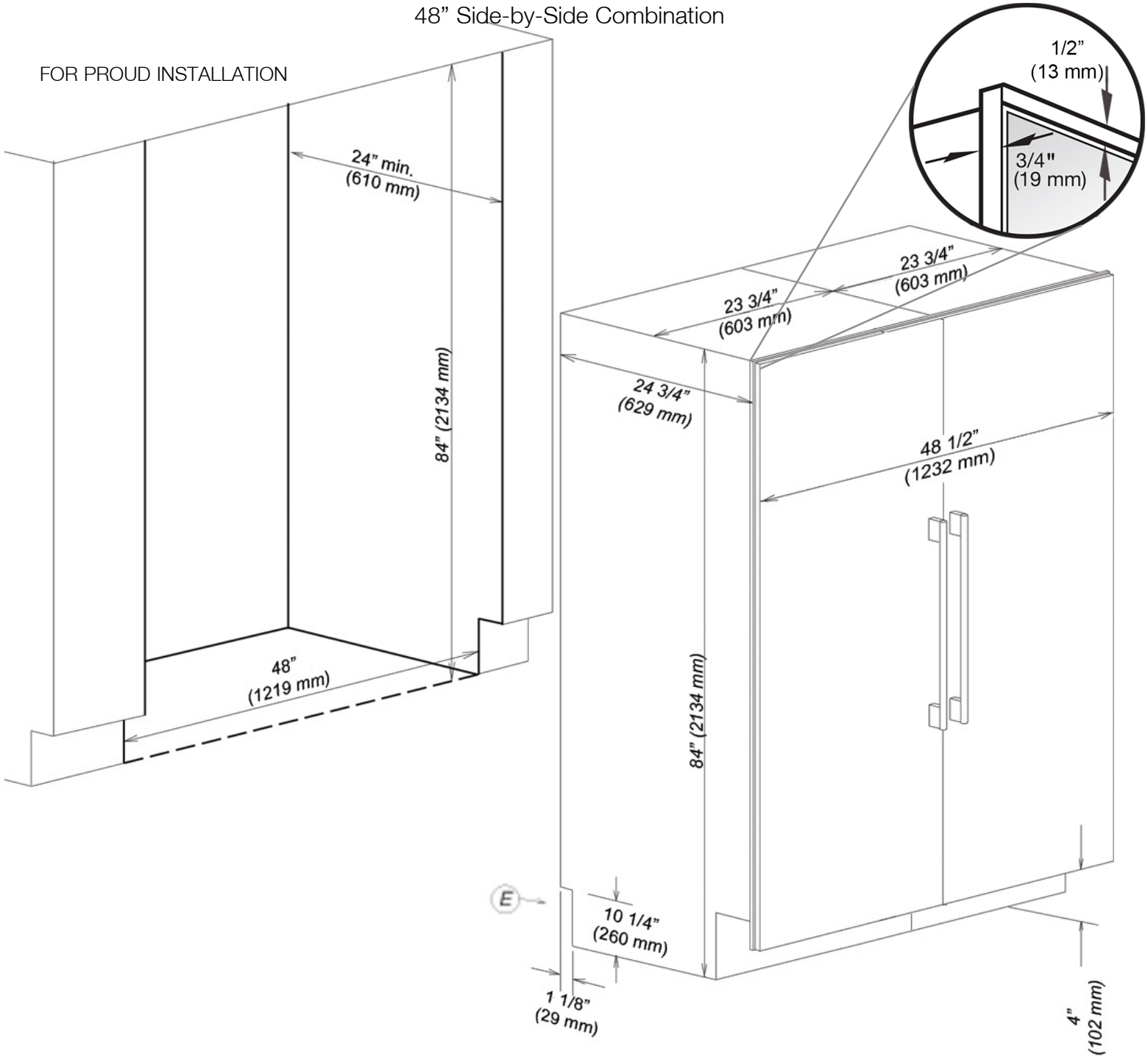

Location Codes

E- power cord for refrigeration unit- 5 foot- NEMA 5-15 molded plug power cord connects lower left rear of units

Notes

- *Merging kit must be used when combining units*
- *KFT1048SS top frame piece must be used when combining units*
- *All Installations must be done in accordance with local codes*
- *Sides of adjoining cabinets should be filled (flush to frame) to insure proper fit and finish*

Product and Cut-out Dimensions 54" Side-by-Side Combination

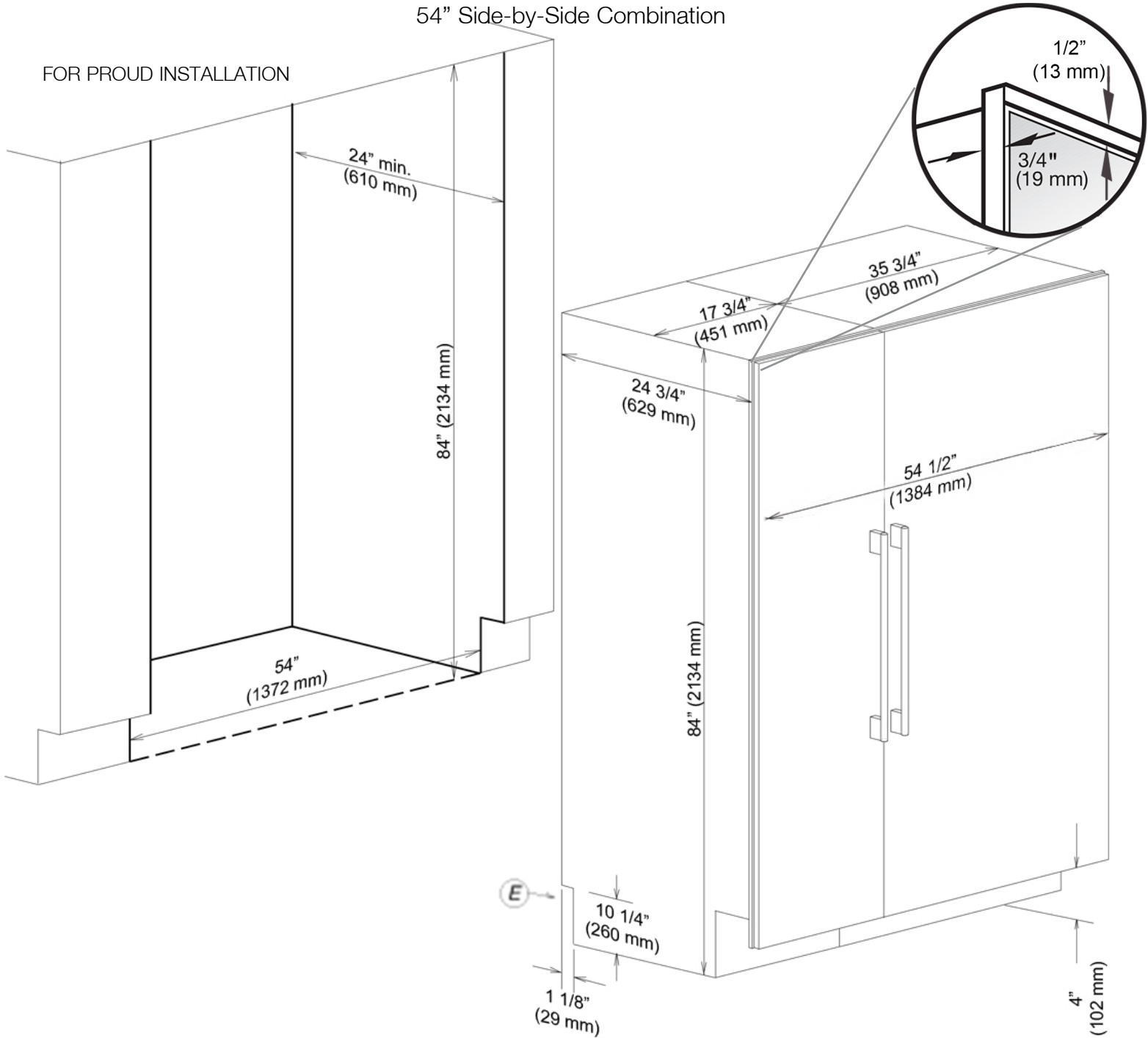

Location Codes

E- power cord for refrigeration unit- 5 foot- NEMA 5-15 molded plug power cord connects lower left rear of units

Notes

- Merging kit must be used when combining units
- KFT1054SS top frame piece must be used when combining units
- All Installations must be done in accordance with local codes
- Sides of adjoining cabinets should be filled (flush to frame) to insure proper fit and finish

Product and Cut-out Dimensions 54" Side-by-Side Combination

FOR PROUD INSTALLATION

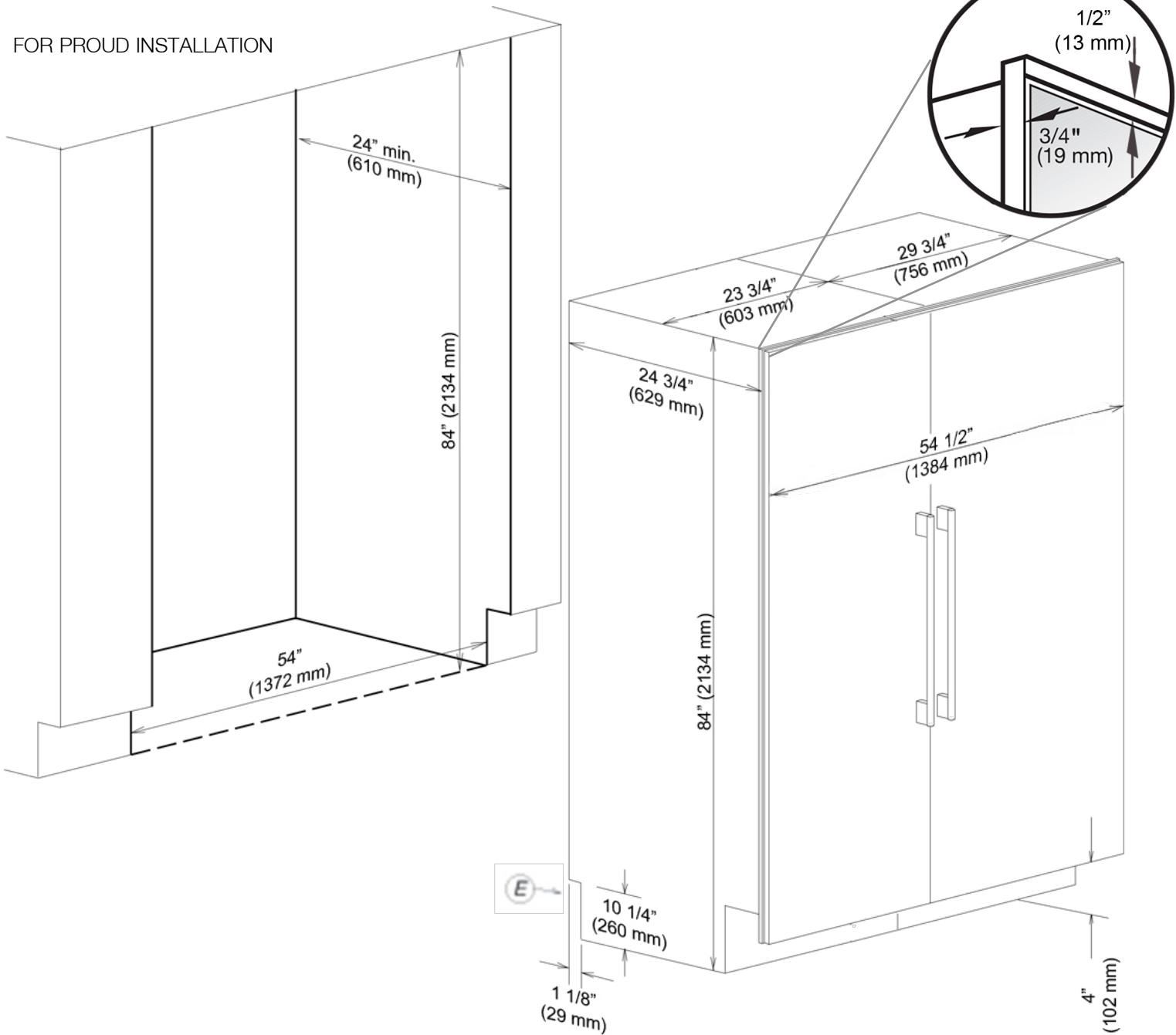

Location Codes

E- power cord for refrigeration unit- 5 foot- NEMA 5-15 molded plug power cord connects lower left rear of units

Notes

- Merging kit must be used when combining units
- KFT1054SS top frame piece must be used when combining units
- All Installations must be done in accordance with local codes
- Sides of adjoining cabinets should be filled (flush to frame) to insure proper fit and finish

Product and Cut-out Dimensions
60" Side-by-Side Combination

FOR PROUD INSTALLATION

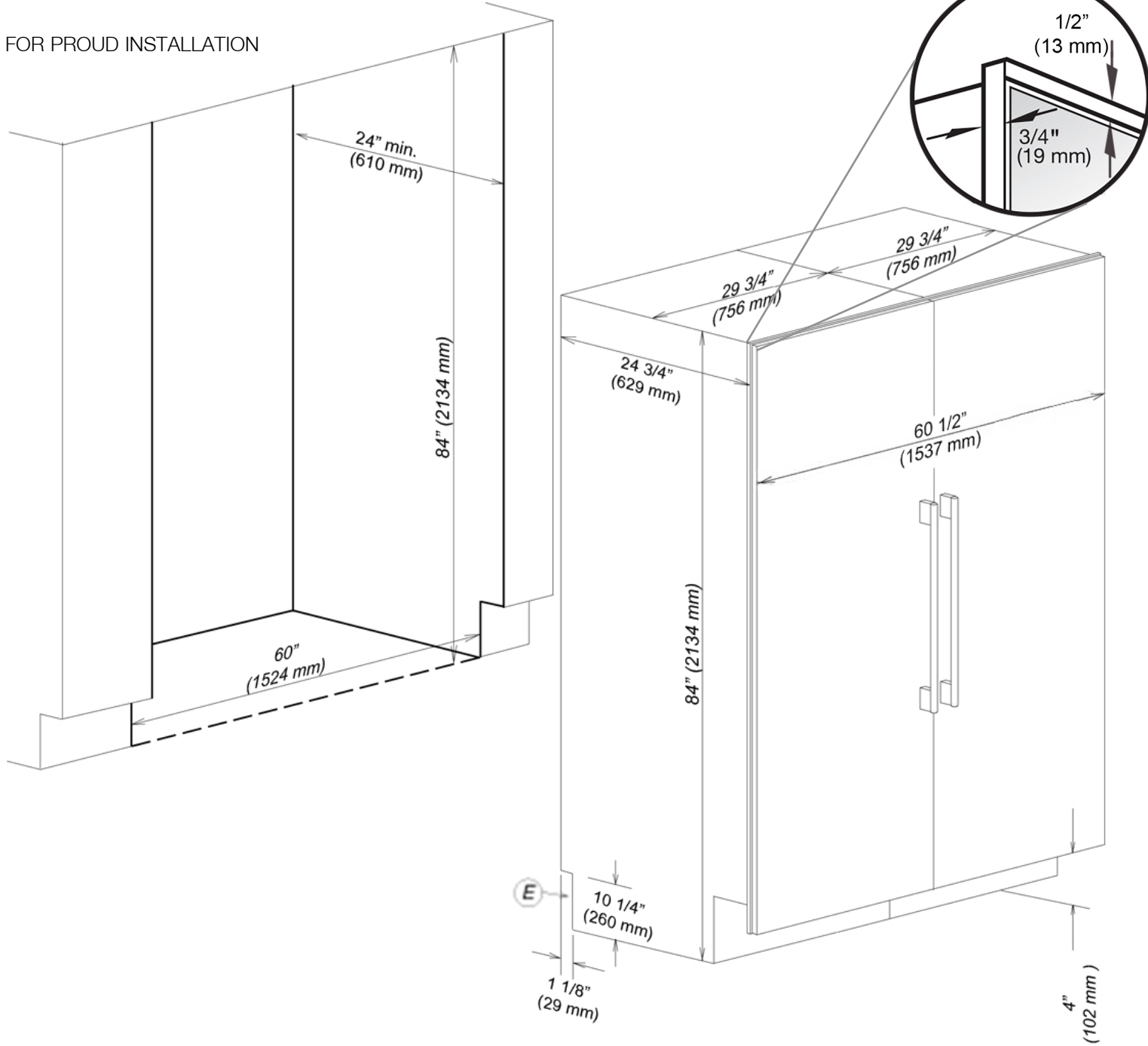

Location Codes

E- power cord for refrigeration unit- 5 foot- NEMA 5-15 molded plug power cord connects lower left rear of units

Notes

- Merging kit must be used when combining units
- KFT1060SS top frame piece must be used when combining units
- All Installations must be done in accordance with local codes
- Sides of adjoining cabinets should be filled (flush to frame) to insure proper fit and finish

Product and Cut-out Dimensions
60" Side-by-Side Combination

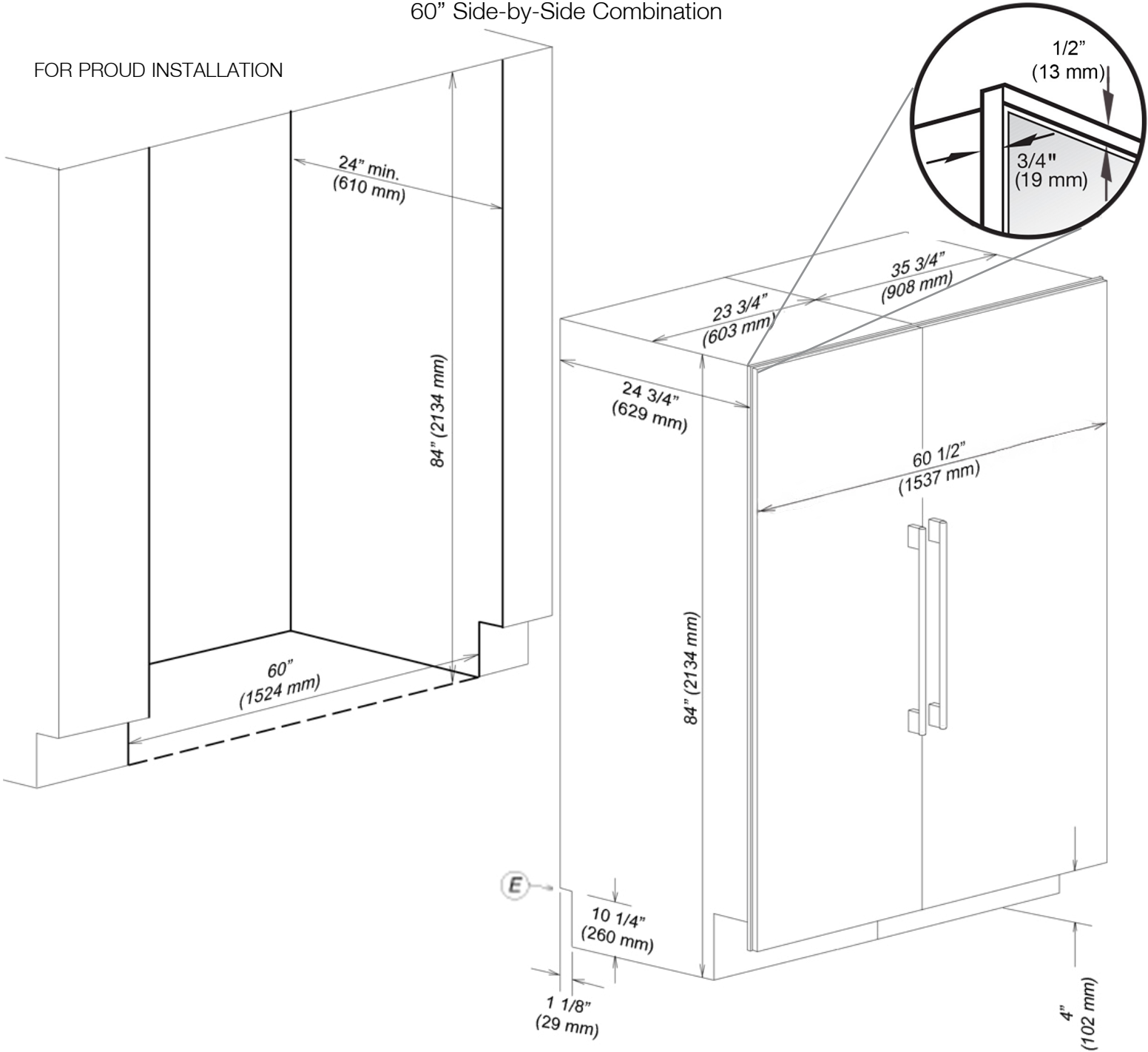

Location Codes

E- power cord for refrigeration unit- 5 foot- NEMA 5-15 molded plug power cord connects lower left rear of units

Notes

- Merging kit must be used when combining units
- KFT1060SS top frame piece must be used when combining units
- All Installations must be done in accordance with local codes
- Sides of adjoining cabinets should be filled (flush to frame) to insure proper fit and finish

Product and Cut-out Dimensions 66" Side-by-Side Combination

FOR PROUD INSTALLATION

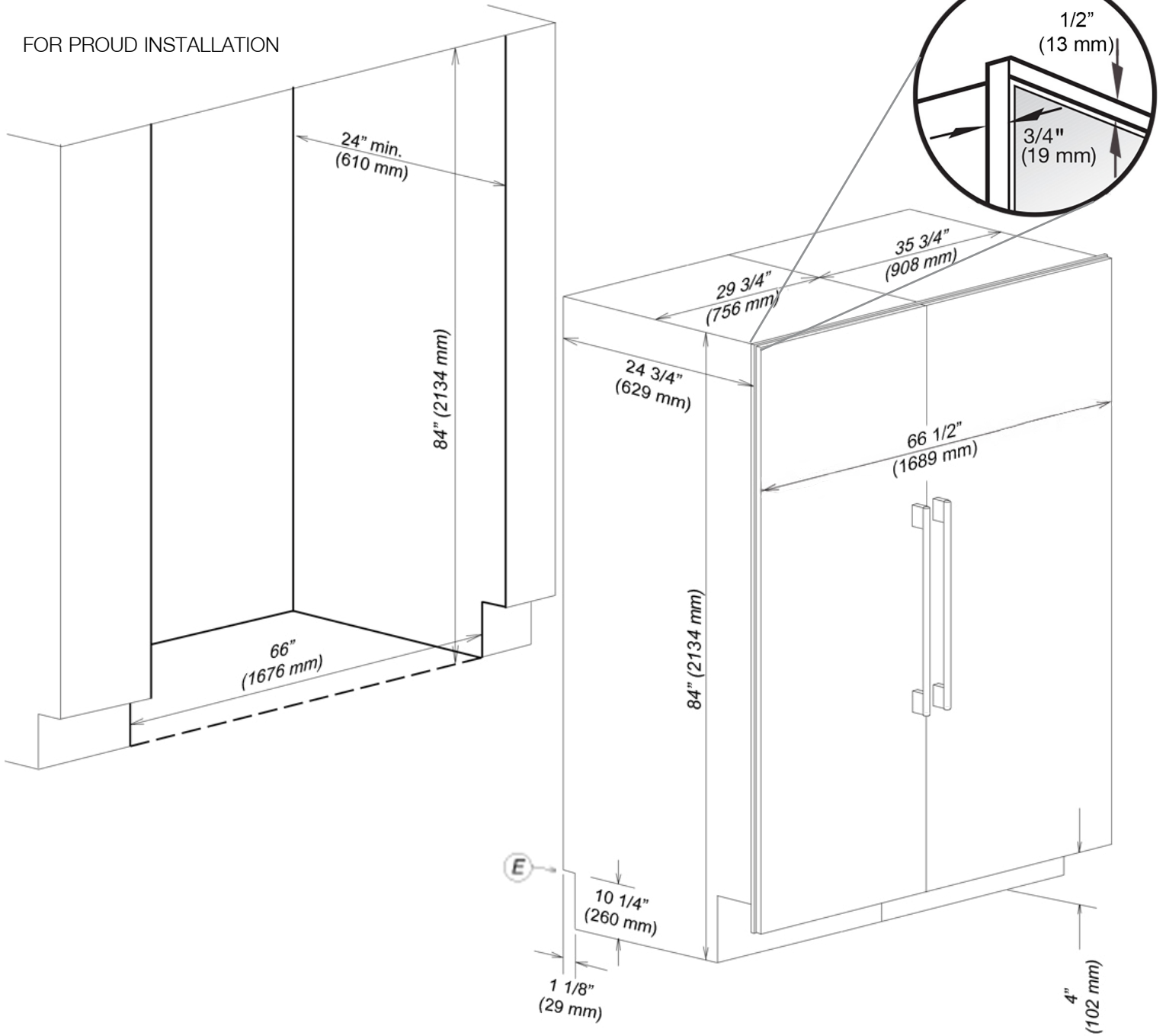

Location Codes

E- power cord for refrigeration unit- 5 foot- NEMA 5-15 molded plug power cord connects lower left rear of units

Notes

- Merging kit must be used when combining units
- KFT1066SS top frame piece must be used when combining units
- All installations must be done in accordance with local codes
- Sides of adjoining cabinets should be filled (flush to frame) to insure proper fit and finish

Product and Cut-out Dimensions
72" Side-by-Side Combination

FOR PROUD INSTALLATION

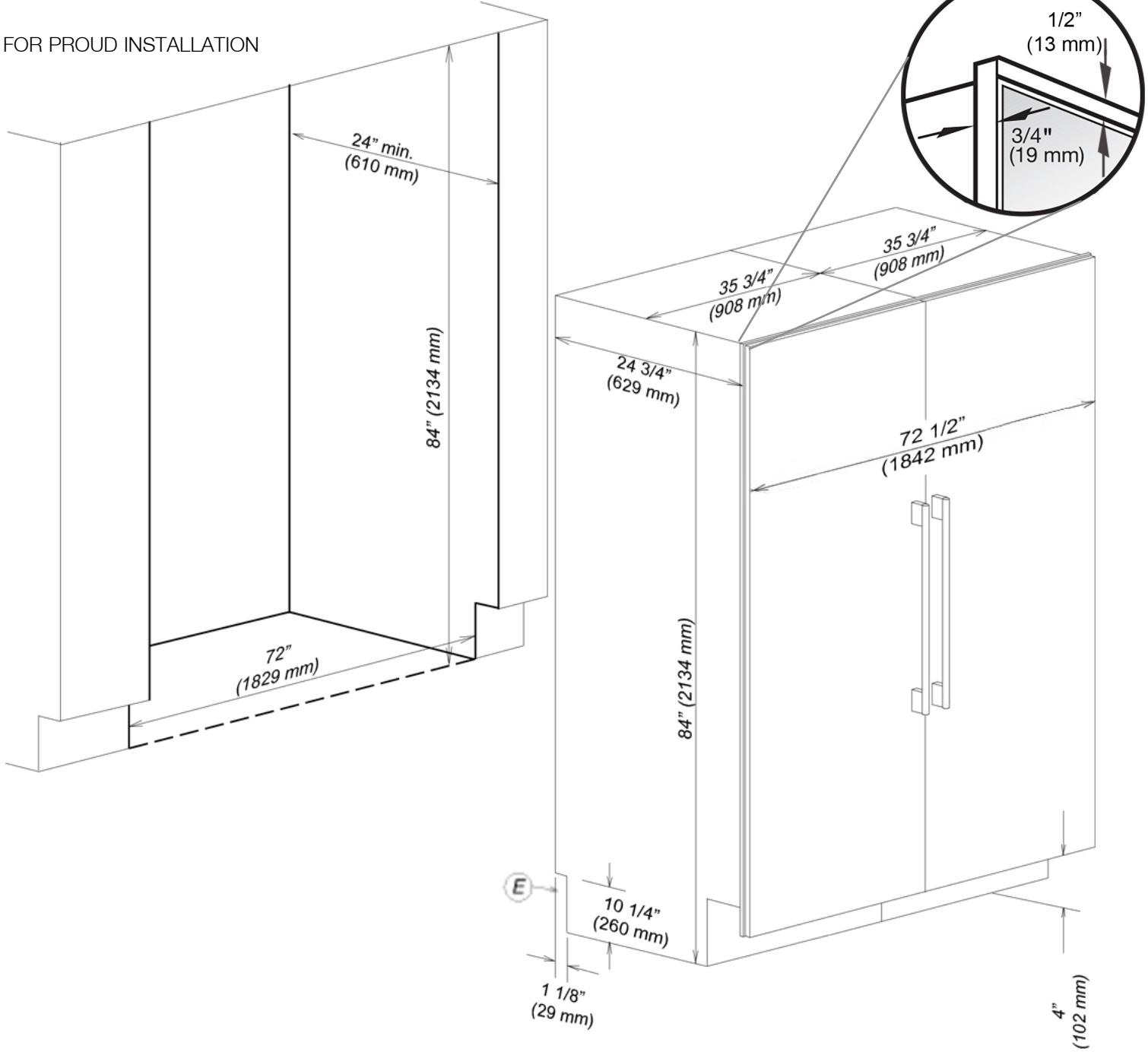

Location Codes

E- power cord for refrigeration unit- 5 foot- NEMA 5-15 molded plug power cord connects lower left rear of units

Notes

- Merging kit must be used when combining units
- KFT1072SS top frame piece must be used when combining units
- All Installations must be done in accordance with local codes
- Sides of adjoining cabinets should be filled (flush to frame) to insure proper fit and finish